



Fixed Frequency White LED Step-Up Converter

● Features

- High Efficiency: Up to 90%
- 1.2MHz Constant Frequency Operation
- Low 104mV Feedback Voltage
- Soft-start/Dimming with wide Frequency Range
- UVLO, Thermal Shutdown
- Internal Current limit
- Over Voltage Protection
- Small LC Filter
- Minimize the External Component
- <math><1\mu\text{A}</math> Shutdown Current

● Applications

- Camera Flash White LED
- Mobile Phone, Smart Phone LED Backlight
- PDA LED Backlight

● General Description

The FS1708 is a step-up converter designed for driving up to 8 series white LEDs from a single cell Lithium Ion battery. The FS1708 uses current mode, fixed frequency architecture to regulate an LED current, which is measured through an external current sense resistor. Its low 104mV feedback voltage reduces power loss and improves efficiency.

The FS1708 includes under-voltage lockout, current limiting and thermal overload protection preventing damage in the event of an output overload. Optimized operation frequency can meet the requirement of small LC filters value and low operation current with high efficiency. Internal soft start function can reduce the inrush current. Tiny package type provide the best solution for PCB space saving and total BOM cost.

● Pin Configurations

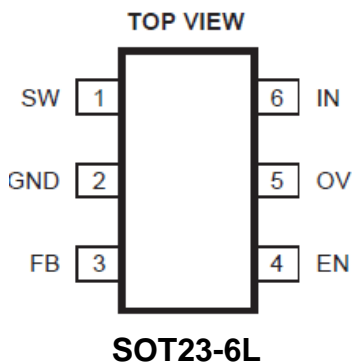

● Typical Application Circuit

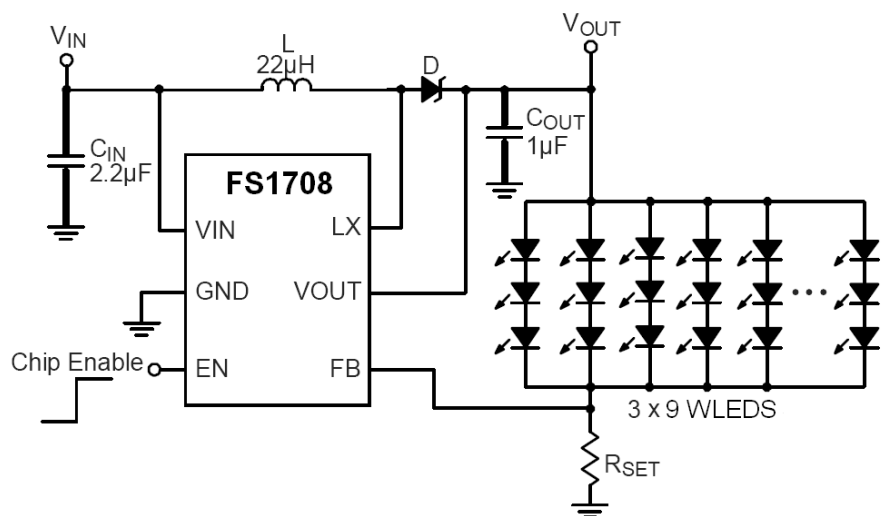



- Absolute Maximum Ratings**

| Parameter | Ratings |
|---------------------------------------|----------------|
| VCC, SHDN to GND. | -0.3V to +6 V |
| FB to GND | -0.3V to VCC |
| SW, OVP to GND | -0.3V to +35V |
| Operating Temperature | -40°C to 85°C |
| Junction Temperature | 125°C |
| Storage Temperature | -65°C to 150°C |
| Reflow Temperature (soldering, 10sec) | 260°C |
| ESD Rating (Human Body Model) | 2kV |

Stress beyond those listed under "Absolute Maximum Rating" may cause permanent damage to the device.

- Electrical Characteristics @ (VCC=V SHDN =3.6V, TA=25°C, unless otherwise specified)**

| Parameter | Conditions | MIN | TYP | MAX | unit |
|----------------------------------|--|-----|-------|------|------|
| Input Voltage Range | | 2.5 | | 5.5 | V |
| UVLO Threshold | | | 2.2 | 2.45 | V |
| Under Voltage Lockout Hysteresis | | | 100 | | mV |
| Shutdown Current | V _{EN} <0.4V | | 0.1 | 1 | uA |
| Quiescent Current | V _{FB} =0.15V, No switch | | 200 | 300 | μA |
| Supply Current | V _{FB} =0V, switch | | 0.6 | 1 | mA |
| Regulated Feedback Voltage | | 94 | 104 | 114 | mV |
| Oscillation Frequency | | | 1.2 | | MHz |
| ON Resistance of NMOS | | | 0.5 | | Ω |
| Peak Current Limit | V _{IN} = 4.2V, Duty cycle=50% | | 1.5 | | A |
| EN Shutdown Voltage | | | | 0.4 | V |
| EN Enable Voltage | | 1.5 | | | V |
| EN Leakage Current | | | ±0.01 | ±1.0 | μA |
| OVP Threshold | V _{ov} Rising | | 28 | | V |



● Typical Block Diagram

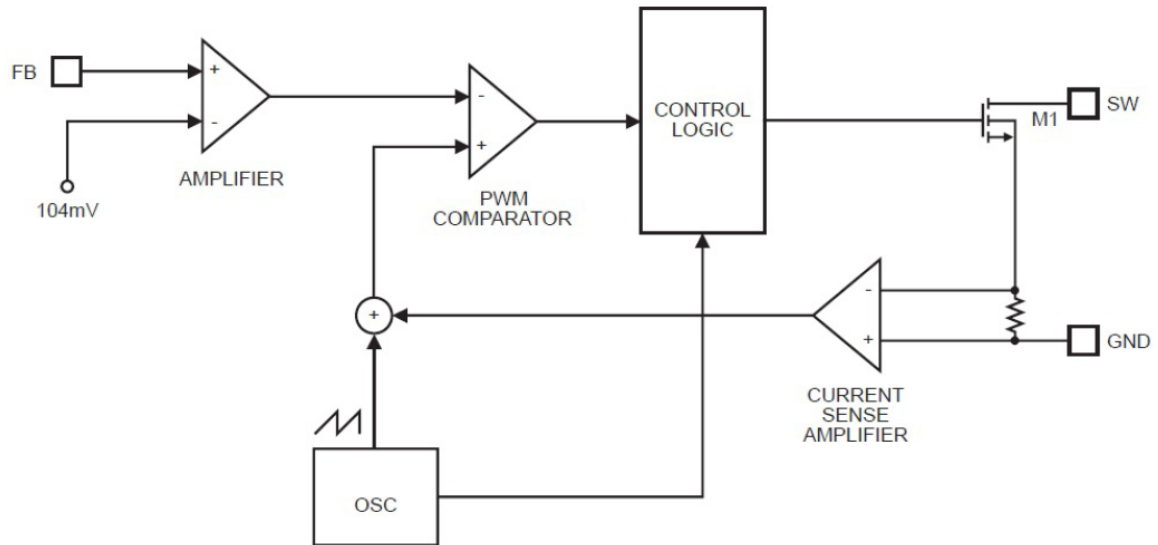

● Pin Description

| Pin | Name | Function |
|-----|------|--|
| 1 | SW | Switch Pin. The drain of the internal NMOS power switch. Connect this pin to inductor. |
| 2 | GND | Ground Pin. |
| 3 | FB | Feedback Pin. Connect current setting resistor R_s from this pin to ground. The LED current is set as $0.104V / R_s$. |
| 4 | SHDN | Active Low Shutdown Pin. |
| 5 | OVP | Over Voltage Protection Sense Pin. |
| 6 | VCC | Input Supply Pin. Bypass this pin with a capacitor as close to the device as possible. |

● Function Description

The FS1708 uses a constant frequency control scheme to provide excellent line and load regulation. Operation can be best understood by referring to the block diagram. At the start of each oscillator cycle, the SR latch is set, which turns on the power switch M1. An artificial ramp is generated to the positive terminal of the PWM comparator. When this voltage exceeds the level at the negative input of comparator, the SR latch is reset turning off the power switch. The level at the negative input of comparator is set by the error amplifier, and is simply an amplified version of the difference between the feedback voltage and the reference voltage of 0.104V. In this manner, the error amplifier sets the correct peak current level to keep the output in regulation. If the error amplifier's output increases, more current is delivered to the output, if it decreases, less current is delivered.

Over voltage protection function is designed to prevent the damage of internal NMOS switch in case the increased impedance of the LED load (include the LED opened). Once the device detects over voltage (typical 30V) at the output, the internal NMOS switch is kept off until the output voltage drops.



● Application Information

Inductor Selection

The recommended value of inductor are 4.7 to 22 μ H. Small size and better efficiency are the major concerns for portable device, such as FS1708 used for mobile phone. The inductor should have low core loss at 1.2MHz and low DCR for better efficiency. To avoid inductor saturation current rating should be considered.

Since the FS1708 is designed to operate in discontinuous mode, the inductor current reaches zero during discharge phase. After the inductor current reaches zero, the switch pin exhibits ringing due to the LC tank circuit formed by the inductor in combination with switch and diode capacitance. This ringing is not harmful; far less spectral energy is contained in the ringing than in the switch transitions. The ringing can be damped by application of a 300 Ω resistor across the inductor, although this will degrade efficiency.

Capacitor Selection

The small size of ceramic capacitors makes them suitable for FS1708 applications. X5R and X7R types are recommended because they retain their capacitance over wider voltage and temperature ranges than other types such as Y5V or Z5U. A minimum 1 μ F capacitor for output is required for most applications. Larger input/output capacitor minimizes input/output ripple.

Diode Selection

Schottky diodes, with their low forward voltage drop and fast reverse recovery, are the ideal choices for FS1708 applications. The forward voltage drop of a Schottky diode represents the conduction losses in the diode, while the diode capacitance (CT or CD) represents the switching losses. For diode selection, both forward voltage drop and diode capacitance need to be considered. Schottky diodes with higher current ratings usually have lower forward voltage drop and larger diode capacitance, which can cause significant switching losses at the 1.2MHz switching frequency of the FS1708. A Schottky diode rated at 500mA is sufficient for most FS1708 applications.

Dimming Control

a. Using a PWM Signal to EN Pin For controlling the LED brightness, the FS1708 can perform the dimming control by applying a PWM signal to EN pin. The internal soft start and the wide range dimming frequency can eliminate inrush current and audio noise when dimming. The average LED current is proportional to the PWM signal duty cycle. The magnitude of the PWM signal should be higher than the maximum enable voltage of EN pin, in order to let the dimming control perform correctly for preventing the flicker issue, the suggested PWM frequency is $\geq 1\text{kHz}$ or $\leq 200\text{Hz}$.

b. Using a DC Voltage Using a variable DC voltage to adjust the brightness is a popular method in some applications. According to the Superposition Theorem, as the DC voltage increases, the voltage contributed to VFB increases and the voltage drop on R2 decreases, i.e. the LED current decreases. For example, if the VDC range is from 0V to 2.8V, the selection of resistors sets dimming control of LED current from 20mA to 0mA.

c. Using a Filtered PWM signal Another common application is using a filtered PWM signal as an adjustable DC voltage for LED dimming control. A filtered PWM signal acts as the DC voltage to regulate the output current. In this circuit, the output ripple depends on the frequency of PWM signal. For smaller output voltage ripple (<100mV), the recommended frequency of 2.8V PWM signal should be above 2kHz. To fix the frequency of PWM signal and change the duty cycle of PWM signal can get different output current.



Typical Performance Characteristics

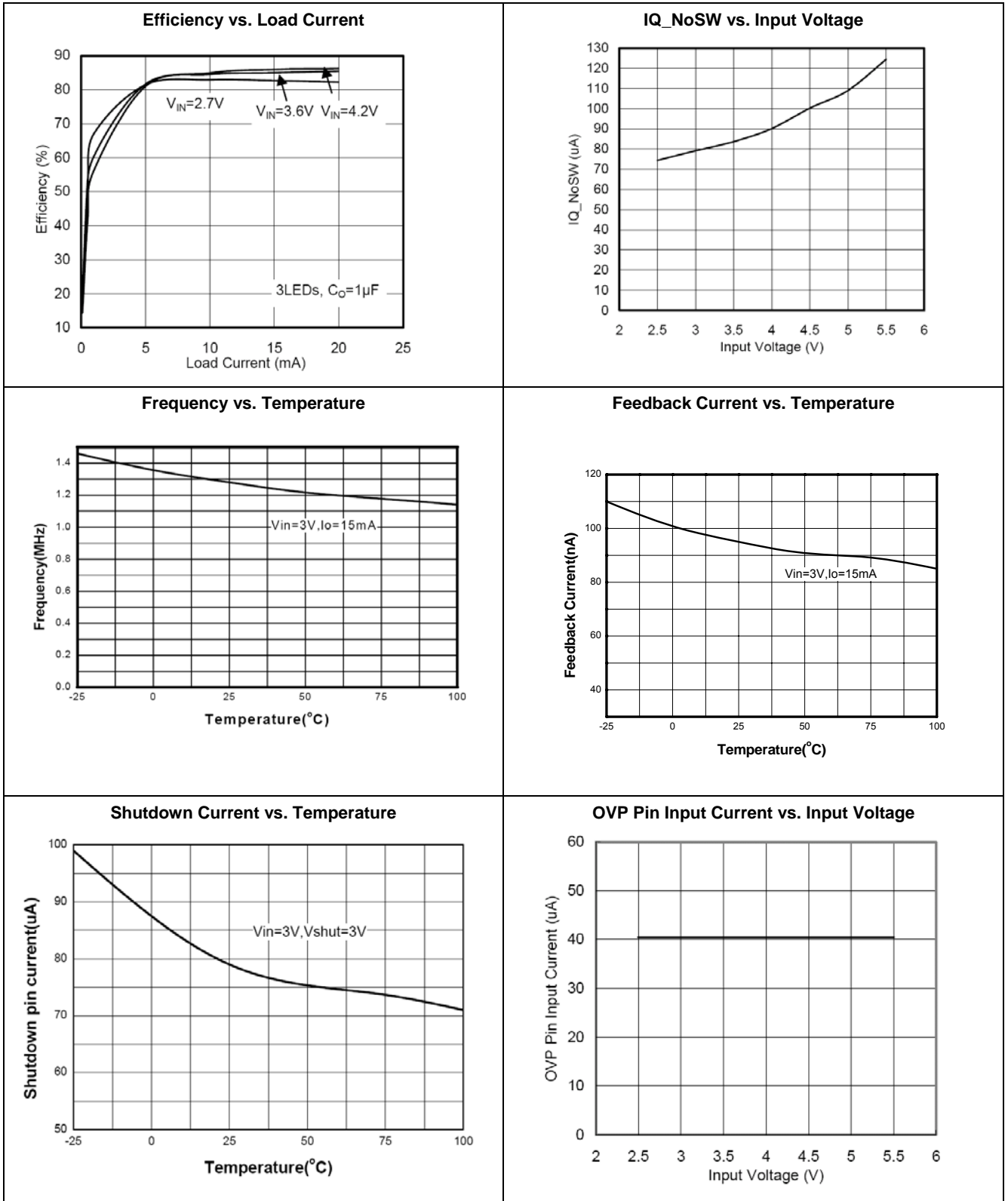



● Package Information

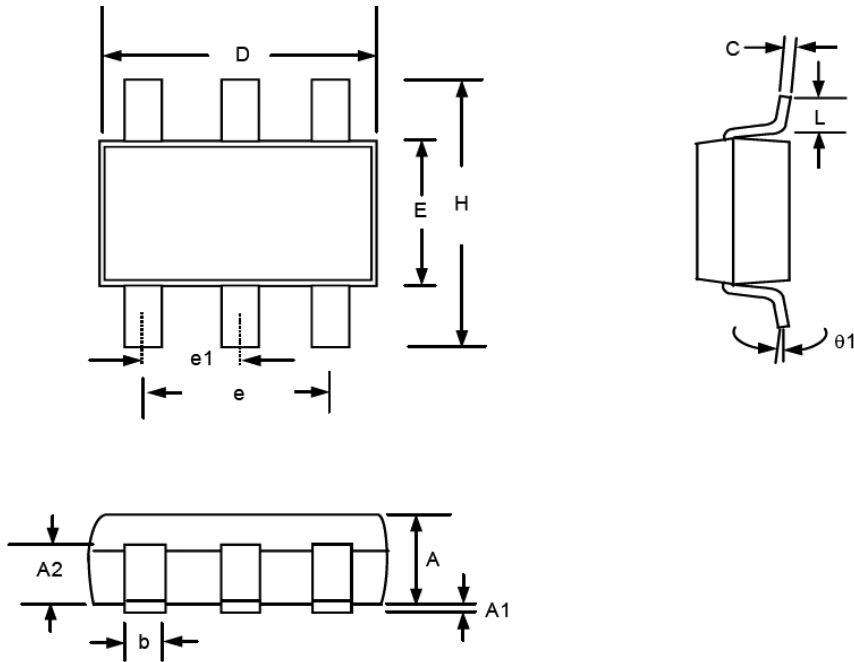

| Symbol | Dimension mm | | | Dimension in inch | | |
|------------|--------------|-----------|------|-------------------|------------|-------|
| | Min | Nom | Max | Min | Nom | Max |
| A | 1.00 | 1.10 | 1.30 | 0.039 | 0.043 | 0.051 |
| A1 | 0.00 | | 0.10 | 0.000 | | 0.004 |
| A2 | 0.70 | 0.80 | 0.90 | 0.028 | 0.031 | 0.035 |
| b | 0.35 | 0.40 | 0.50 | 0.014 | 0.016 | 0.020 |
| C | 0.10 | 0.15 | 0.25 | 0.004 | 0.006 | 0.010 |
| D | 2.70 | 2.90 | 3.10 | 0.106 | 0.114 | 0.122 |
| E | 1.40 | 1.60 | 1.80 | 0.055 | 0.063 | 0.071 |
| e | | 1.90(TYP) | | | 0.075(TYP) | |
| H | 2.60 | 2.80 | 3.00 | 0.102 | 0.110 | 0.118 |
| L | 0.37 | | | 0.015 | | |
| $\theta 1$ | 1° | 5° | 9° | 1° | 5° | 9° |