



# 1A Three-terminal positive voltage regulator

- Features

Maximum Output current  $I_{OM}$ : 1 A

Output voltage  $V_o$ : 5V, 9V, 12V, 15V

- Pin Configurations

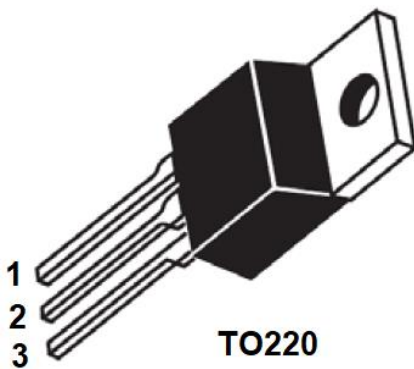

1:IN 2:GND 3:OUT

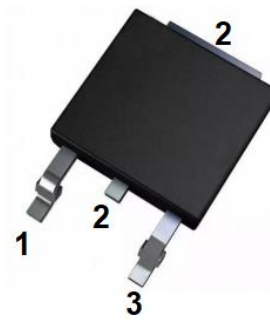

1:IN 2:GND 3:OUT

- Absolute Maximum Ratings

@ $T_A=25^\circ\text{C}$  unless otherwise noted

Parameter	Symbol	Ratings	Unit
Input Voltage	$V_i$	35	V
Operating Junction Temperature Range	$T_{OPR}$	0-+125	$^\circ\text{C}$
Storage Temperature Range	$T_{STG}$	-65-+150	$^\circ\text{C}$
Thermal Resistance Junction-Cases	$R_{\theta JC}$	5	$^\circ\text{C/W}$
Thermal Resistance, Junction-to-Ambient	$R_{\theta JC}$	65	$^\circ\text{C/W}$

- Ordering information

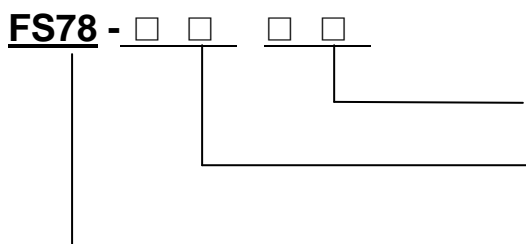

Package type

T0=TO220; T2=TO252;

Output Voltage

... 05=5.0V 09=9.0V 12=12V 15=15V...

Indicates the product number



● **Electrical Characteristics**

(Unless otherwise specified:  $I_O = 500\text{mA}$ ,  $V_I = 14\text{V}$ ,  $C_{IN} = 0.33\ \mu\text{F}$ ,  $C_O = 0.1\ \mu\text{F}$ ) **FS7805**

Parameter	Symbol	Conditions	Min	Typ	Max	Unit	
Output Voltage	VO	T <sub>J</sub> = 25 5mA ≤ I <sub>O</sub> ≤ 1A, P <sub>O</sub> ≤ 15W, V <sub>I</sub> = 7V to 20V	4.8	5.0	5.2	V	
			4.75	5.0	5.25		
Line Regulation (Note 2)	Regline	T <sub>J</sub> = 25°C	VO = 7V to 25V	–	4.0	100	mV
			VI = 8V to 12V	–	1.6	50.0	
Load Regulation	Regload	T <sub>J</sub> = 25°C	IO = 5mA to 1.5mA	–	9.0	100	mV
			IO = 250mA to 750mA	–	4.0	50.0	
Quiescent Current	IQ	T <sub>J</sub> = 25°C	–	5.0	8.0	mA	
Quiescent Current Change	ΔIQ	IO = 5mA to 1A	–	0.03	0.5	mA	
		VI = 7V to 25V	–	0.3	1.3		
Output Voltage Drift (Note 3)	ΔVO/ΔT	IO = 5mA	–	-0.8	–	mV/°C	
Output Noise Voltage	VN	f = 10Hz to 100KHz, TA = 25°C	–	42.0	–	μV/VO	
Ripple Rejection (Note 3)	RR	f = 120Hz, VO = 8V to 18V	62.0	73.0	–	dB	
Dropout Voltage	VDROP	IO = 1A, T <sub>J</sub> = 25°C	–	2.0	–	V	
Output Resistance (Note 3)	rO	f = 1KHz	–	15.0	–	mΩ	
Short Circuit Current	ISC	VI = 35V, TA = 25°C	–	230	–	mA	
Peak Current (Note 3)	IPK	T <sub>J</sub> = 25°C	–	2.2	–	A	

( $V_I = 16\text{V}$ ,  $I_O = 500\text{mA}$ ,  $C_i = 0.33\ \mu\text{F}$ ,  $C_o = 0.1\ \mu\text{F}$ , unless otherwise specified) **FS7809**

Parameter	Symbol	Conditions	Min	Typ	Max	Unit	
Output Voltage	VO	T <sub>J</sub> = 25°C 5mA ≤ I <sub>O</sub> ≤ 1A, P <sub>O</sub> ≤ 15W, V <sub>I</sub> = 11.5V to 24V	8.65	9.0	9.35	V	
			8.6	9.0	9.4		
Line Regulation (Note 2)	Regline	T <sub>J</sub> = 25°C	VI = 11.5V to 25V	–	6.0	180	mV
			VI = 12V to 17V	–	2.0	90.0	
Load Regulation (Note 2)	Regload	T <sub>J</sub> = 25°C	IO = 5mA to 1.5mA	–	12.0	180	mV
			IO = 250mA to 750mA	–	4.0	90.0	
Quiescent Current	IQ	T <sub>J</sub> = 25°C	–	5.0	8.0	mA	
Quiescent Current Change	ΔIQ	IO = 5mA to 1A	–	–	0.5	mA	
		VI = 11.5V to 26V	–	–	1.3		
Output Voltage Drift (Note3)	ΔVO/ΔT	IO = 5mA	–	_1.0	–	mV/°C	
Output Noise Voltage	VN	f = 10Hz to 100KHz, TA = 25°C	–	58.0	–	μV/VO	
Ripple Rejection (Note 3)	RR	f = 120Hz, VO = 13V to 23V	56.0	71.0	–	dB	
Dropout Voltage	VDROP	IO = 1A, T <sub>J</sub> = 25°C	–	2.0	–	V	
Output Resistance (Note 3)	rO	f = 1KHz	–	17.0	–	mΩ	
Short Circuit Current	ISC	VI = 35V, TA = 25°C	–	250	–	mA	
Peak Current (Note3)	IPK	T <sub>J</sub> = 25°C	–	2.2	–	A	



( Unless otherwise specified: IO = 500mA, VIN = 19V, CIN = 0.33 μF, CO = 0.1μF ) **FS7812**

Parameter	Symbol	Conditions	Min	Typ	Max	Unit	
Output Voltage	VO	TJ = 25°C 5mA ≤ IO ≤ 1A, PO≤15W, VI = 14.5V to 27V	11.5	12.0	12.5	V	
			11.4	12.0	12.6		
Line Regulation (Note 2)	Regline	TJ = 25°C	VI = 14.5V to 30V	–	10.0	240	mV
			VI = 16V to 22V	–	3.0	120	
Load Regulation (Note 2)	Regload	TJ = 25°C	IO = 5mA to 1.5mA	–	11.0	240	mV
			IO = 250mA to 750mA	–	5.0	120	
Quiescent Current	IQ	TJ = 25°C	–	5.1	8.0	mA	
Quiescent Current Change	ΔIQ	IO = 5mA to 1A VI = 14.5V to 30V	–	0.1	0.5	mA	
			–	0.5	1.0		
Output Voltage Drift (Note 3)	ΔVO/ΔT	IO = 5mA	–	_1.0	–	mV/°C	
Output Noise Voltage	VN	f = 10Hz to 100KHz, TA = 25°C	–	76.0	–	μV/VO	
Ripple Rejection (Note 3)	RR	f = 120Hz, VI = 15V to 25V	55.0	71.0	–	dB	
Dropout Voltage	VDROP	IO = 1A, TJ = 25°C	–	2.0	–	V	
Output Resistance (Note 3)	rO	f = 1KHz	–	18.0	–	mΩ	
Short Circuit Current	ISC	VI = 35V, TA = 25°C	–	230	–	mA	
Peak Current (Note 3)	IPK	TJ = 25°C	–	2.2	–	A	

( Unless otherwise specified: VIN = 23V, CIN = 0.33 μF, CO = 0.1 Mf) **FS7815**

Parameter	Symbol	Conditions	Min	Typ	Max	Unit	
Output Voltage	VO	TJ = 25°C 5mA ≤ IO ≤ 1A, PO≤15W, VI = 17.5V to 30V	14.4	15.0	15.6	V	
			14.25	15.0	15.75		
Line Regulation (Note 2)	Regline	TJ = 25°C	VI = 17.5V to 30V	–	11.0	300	mV
			VI = 20V to 26V	–	3.0	150	
Load Regulation (Note 2)	Regload	TJ = 25°C	IO = 5mA to 1.5mA	–	12.0	300	mV
			IO = 250mA to 750mA	–	4.0	150	
Quiescent Current	IQ	TJ = 25°C	–	5.2	8.0	mA	
Quiescent Current Change	ΔIQ	IO = 5mA to 1A VI = 17.5V to 30V	–	–	0.5	mA	
			–	–	1.0		
Output Voltage Drift (Note 3)	ΔVO/ΔT	IO = 5mA	–	_1.0	–	mV/_C	
Output Noise Voltage	VN	f = 10Hz to 100KHz, TA = 25°C	–	90.0	–	μV/VO	
Ripple Rejection (Note 3)	RR	f = 120Hz, VI = 18.5V to 28.5V	54.0	70.0	–	dB	
Dropout Voltage	VDROP	IO = 1A, TJ = 25°C	–	2.0	–	V	
Output Resistance (Note 3)	rO	f = 1KHz	–	19.0	–	mΩ	
Short Circuit Current	ISC	VI = 35V, TA = 25°C	–	250	–	mA	
Peak Current (Note 3)	IPK	TJ = 25°C	–	2.2	–	A	

Note 1: Electrical specifications do not apply when operating the device outside of its rated operating conditions.

Note 2: Load and line regulation are specified at constant junction temperature. Changes in VO due to heating effects must be taken into account separately. Pulse testing with low duty is used.

Note 3: These parameters, although guaranteed, are not 100% tested in production.



● Internal Block Diagram

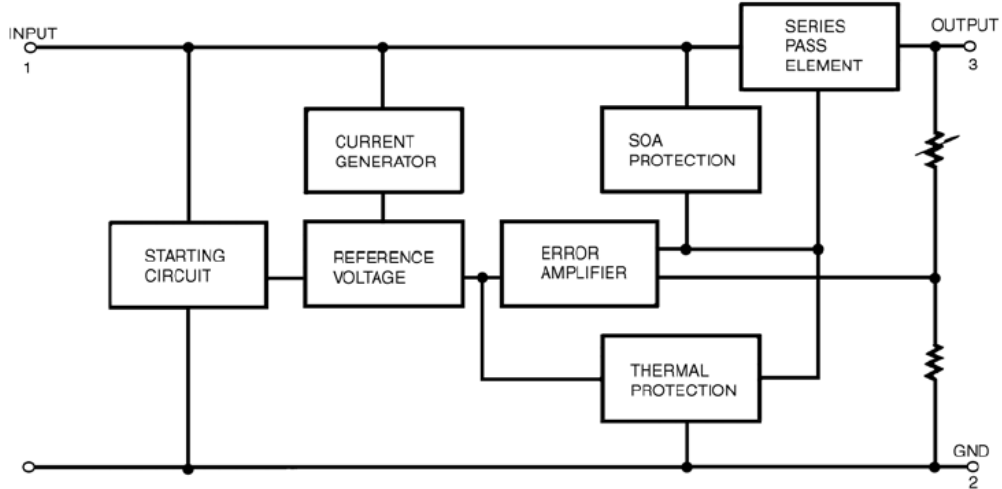

● TYPICAL APPLICATION

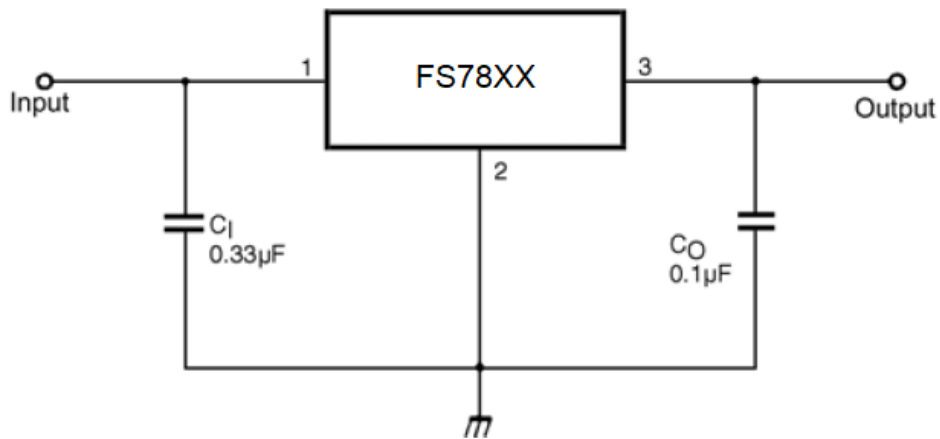

FIGURE A. Fixed Output Regulator

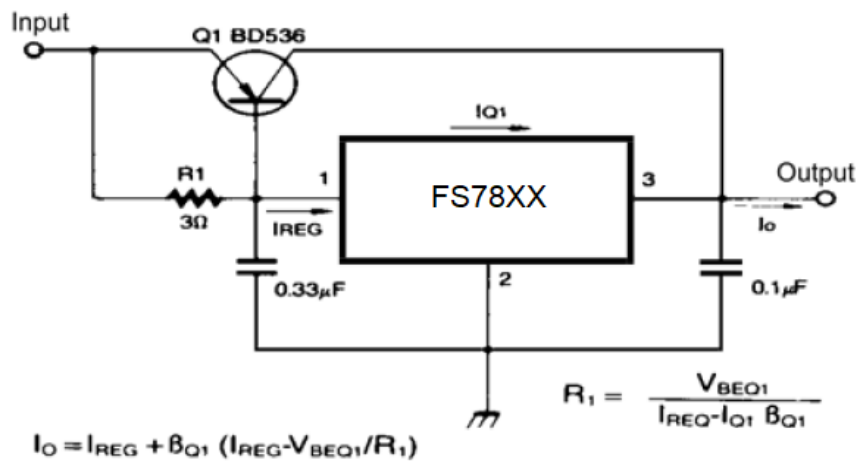

FIGURE B. High Current Voltage Regulator



● Typical Performance Characteristics

(For 7805 TO220 TA=25°C)

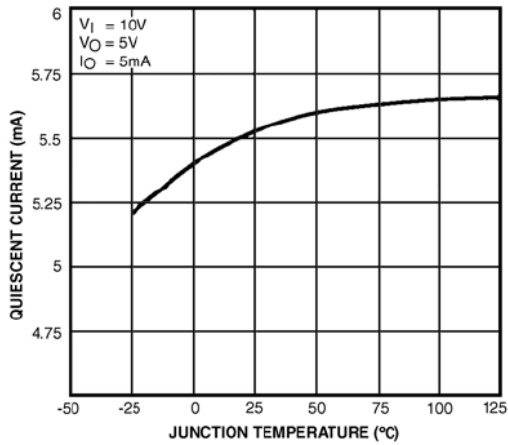

FIGURE 1. Quiescent Current

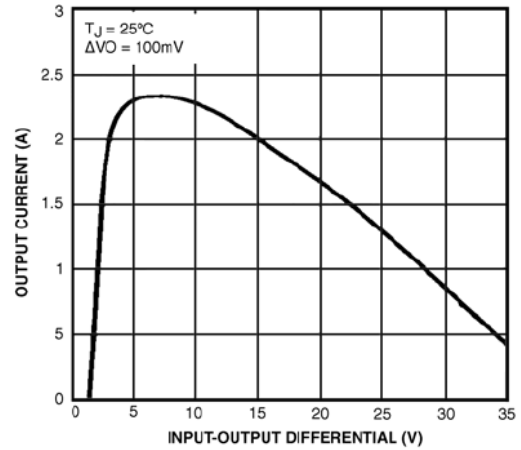

FIGURE 2. Peak Output Current

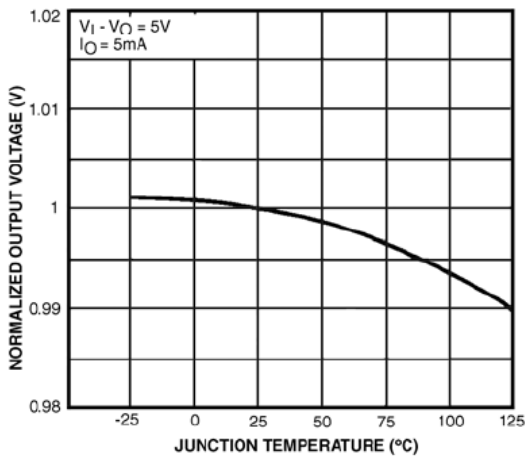

FIGURE 3. Output Voltage

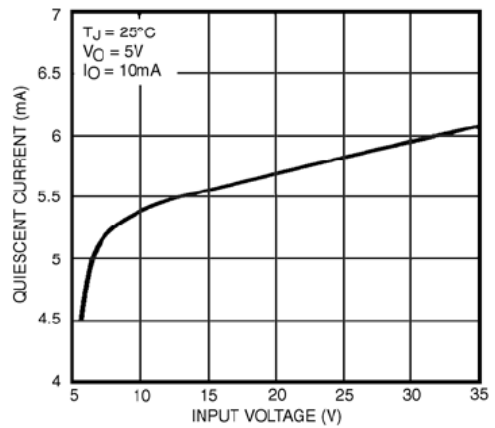
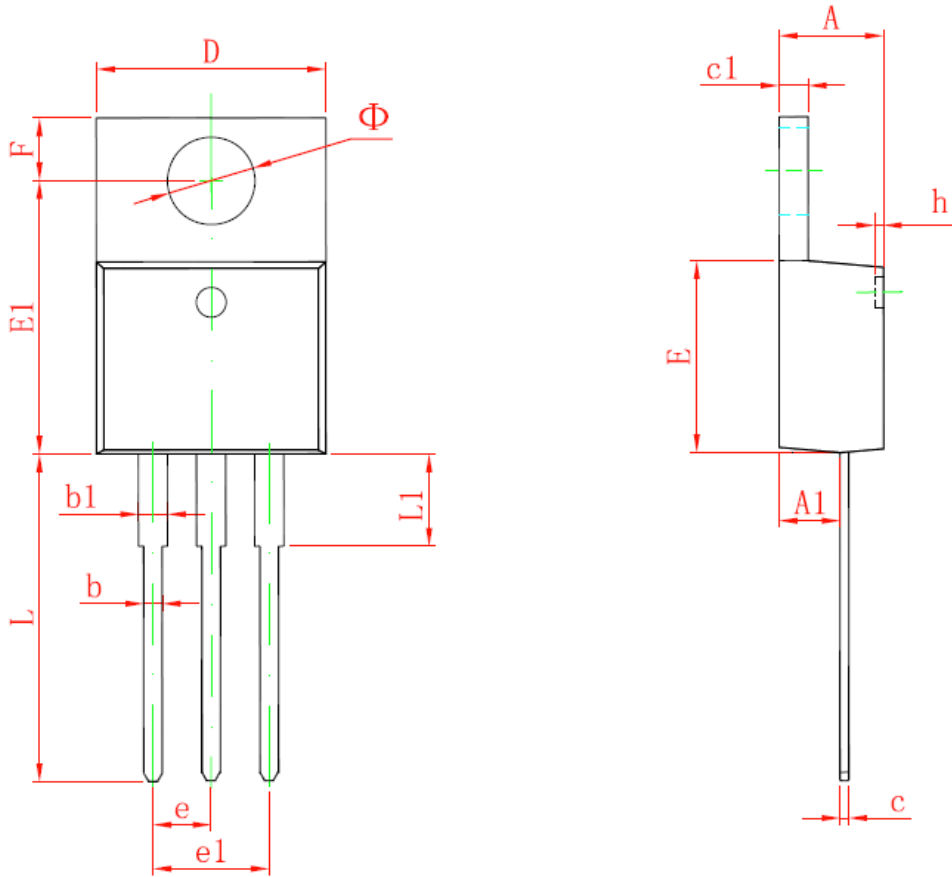

FIGURE 4. Quiescent Current



● **Package Information**

**TO220**



Symbol	Dimensions In Millimeters		Dimensions In Inches	
	Min	Max	Min	Max
A	4.470	4.670	0.176	0.184
A1	2.520	2.820	0.099	0.111
b	0.710	0.910	0.028	0.036
b1	1.170	1.370	0.046	0.054
c	0.310	0.530	0.012	0.021
c1	1.170	1.370	0.046	0.054
D	10.010	10.310	0.394	0.406
E	8.500	8.900	0.335	0.350
E1	12.060	12.460	0.475	0.491
e	2.540 TYP		0.100 TYP	
e1	4.980	5.180	0.196	0.204
F	2.590	2.890	0.102	0.114
h	0.000	0.300	0.000	0.012
L	13.400	13.800	0.528	0.543
L1	3.560	3.960	0.140	0.156
$\Phi$	3.735	3.935	0.147	0.155



**TO-252-2L PACKAGE OUTLINE DIMENSIONS**

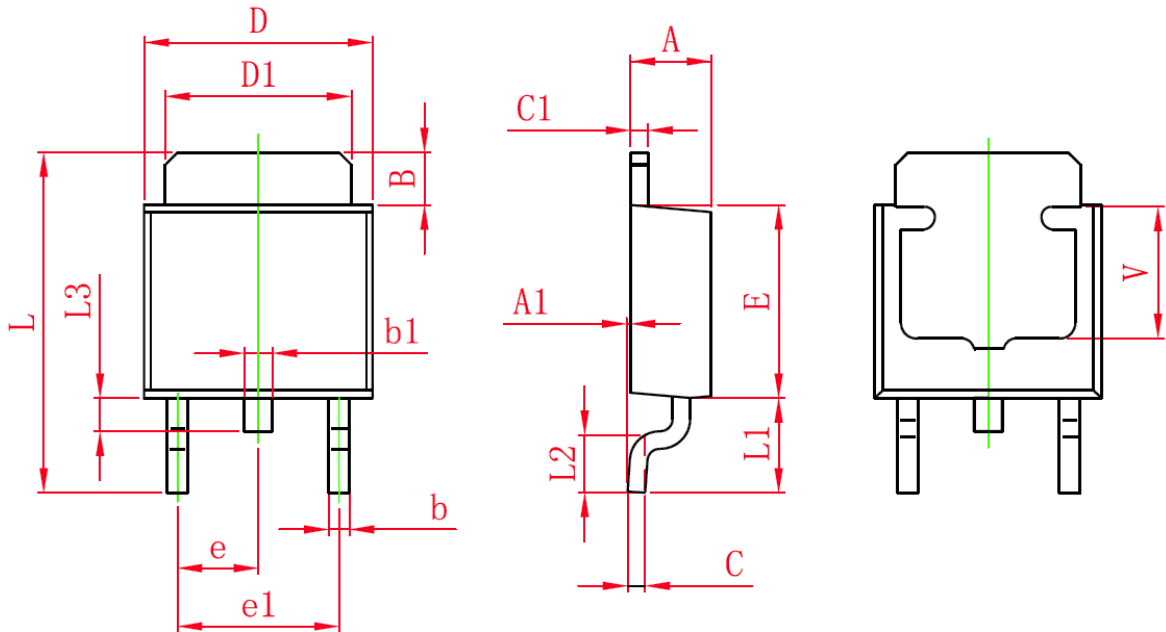

Symbol	Dimensions In Millimeters		Dimensions In Inches	
	Min.	Max.	Min.	Max.
A	2.200	2.400	0.087	0.094
A1	0.000	0.127	0.000	0.005
B	1.350	1.650	0.053	0.065
b	0.500	0.700	0.020	0.028
b1	0.700	0.900	0.028	0.035
c	0.430	0.580	0.017	0.023
c1	0.430	0.580	0.017	0.023
D	6.350	6.650	0.250	0.262
D1	5.200	5.400	0.205	0.213
E	5.400	5.700	0.213	0.224
e	2.300 TYP.		0.091 TYP.	
e1	4.500	4.700	0.177	0.185
L	9.500	9.900	0.374	0.390
L1	2.550	2.900	0.100	0.114
L2	1.400	1.780	0.055	0.070
L3	0.600	0.900	0.024	0.035
V	3.800 REF.		0.150 REF.	