

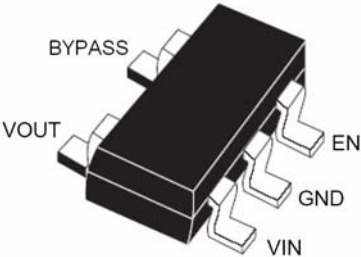

## Low Dropout Linear Regulators Without Reverse Inrush

● <b>Features</b>	● <b>Applications</b>
<p>Low Output Noise: 30<math>\mu</math>VRMS typ(10Hz to 100KHz)            Ultra-Low Dropout Voltage:            300mV at 300mA output            Low 77<math>\mu</math>A No-Load Supply Current            Low 200<math>\mu</math>A Operating Supply Current at 300mA Output            High PSRR (73dB at 1KHz)            Thermal-Overload Protection            Output Current Limit            10nA Logic-Controlled Shutdown            Available in Multiple Output Voltage Versions            Fixed Outputs of 1.8V, 2.5V, 2.8V, 3.0V and 3.3V</p>	<p>Cellular Telephones            Cordless Telephones            PHS Telephones            PCMCIA Cards            Modems            MP3 Player            Hand-Held Instruments            Palmtop Computers            Electronic Planners            Portable/Battery-Powered Equipment</p>
● <b>General Description</b>	
<p>The FS3303B series low-power, low-noise, low-dropout, CMOS linear voltage regulators operate from a 2.5V to 5.5V input and deliver up to 300mA. They are the perfect choice for low voltage, low power applications. An ultra low ground current ( 200<math>\mu</math>A at 300mA output ) makes these part attractive for battery operated power systems. The FS3303B series also offer ultra low dropout voltage (300mV at 300mA outp life in portable electronics. Systems requiring a quiet voltage source, such as RF applications, will benefit from the FS3303B series' ultra low output noise (30<math>\mu</math>VRMS) and high PSRR. An external noise bypass capacitor connected to the device's BP pin can further reduce the noise level.</p> <p>The output voltage is preset to voltages in the range of 1.5V to 3.3V. Other features include a 10nA logic-controlled shutdown mode, foldback current limit and thermal shutdown protection.</p> <p>Devices come in 5-pin SOT23 package.</p>	
● <b>Pin Configurations</b>	● <b>Typical Application Circuit</b>
 <p style="text-align: center;"><b>SOT23-5L</b></p>	

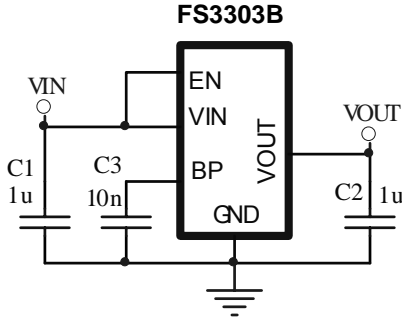

● Absolute Maximum Ratings

Parameter	Symbol	Ratings	Unit
IN Supply Voltage	VIN	-0.3 TO 6	V
OUT Voltage	VOUT	-0.3V to VIN+0.3	V
EN Voltage		-0.3V to 6	V
Continuous OUT Current	IMAX	Internally limited	
Power Dissipation ( TAMB = 25°C)	PD	300	mW
Operating Temperature	TOPR	-25 to +125	°C
Storage Temperature Range	TSTG	-65 to +150	°C

● Electrical Characteristics

(VIN = VOUT (NOMINAL) + 0.5V (1), TA = - 40°C to +125°C, unless otherwise noted. Typical values are at TA = + 25°C.)

PARAMETER	SYMBOL	CONDITIONS	MIN	TYP	MAX	UNITS
Input Voltage	VIN		2.5		5.5	V
Output Voltage Accuracy(1)		IOUT = 1mA to 300mA, TA = +25° C VOUT + 0.5V ≤ VIN ≤ 5.5V	-3		+3	%
Maximum Output Current			300			mA
Current Limit	ILIM		310	750		mA
Ground Pin Current	IQ	No load, EN = 2V		77	145	µA
		IOUT = 300mA, EN = 2V		200		
Dropout Voltage (2)		IOUT = 1mA		0.8		mV
		IOUT = 300mA		300	380	
Line Regulation(1)	Δ VLNR	VIN = 2.5V or (VOUT + 0.5V) to 5.5V, IOUT = 1mA		0.03	0.15	%/V
Load Regulation	Δ VLDR	IOUT = 0.1mA to 300mA, COUT = 1µF		0.0008	0.002	%/mA
Output Voltage Noise	en	f = 10Hz to 100KHz, CBP = 0.01µF, COUT = 10µF		30		µVRMS
Power Supply Rejection Rate	PSRR	CBP = 0.1µF, ILOAD = 50mA, COUT = 1µF	f = 100Hz,		78	dB
			f = 1KHz,		73	
EN Input Threshold	VIH	VIN = 2.5V to 5.5V	2.0			V
	VIL				0.4	
EN Input Bias Current	IB(SHDN)	EN = 0V and EN = 5.5V	TA = +25°C	0.01	1	µA
			TA = +125°C	0.01		
Shutdown Supply Current	IQ(SHDN)	EN = 0.4V	TA = +25°C	0.01	1	µA
			TA = +125°C	0.01		
Shutdown Exit Delay(3) No load		CBP = 0.01µF COUT = 1µF,	TA = +25°C	30		µs
Thermal Shutdown	TSHDN			160		°C



**FOR SEMI**

**FS3303B**

Temperature					
Thermal Shutdown Hysteresis	$\Delta$ TSHDN		15		°C

Note 1:  $V_{IN} = V_{OUT}(\text{NOMINAL}) + 0.5V$  or  $2.5V$ , whichever is greater.

Note 2: The dropout voltage is defined as  $V_{IN} - V_{OUT}$ , when  $V_{OUT}$  is  $100mV$  below the value of  $V_{OUT}$  for  $V_{IN} = V_{OUT} + 0.5V$ . (Only applicable

for  $V_{OUT} = +2.5V$  to  $+5.0V$ .)

Note 3: Time needed for  $V_{OUT}$  to reach 95% of final value.

● **Typical Block Diagram**

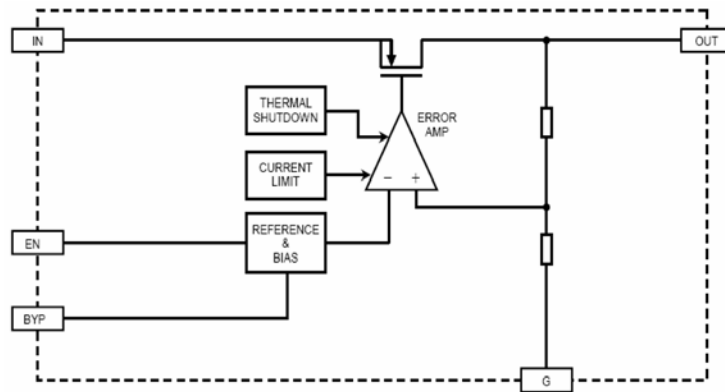

● **Pin Description**

PIN	NAME	FUNCTION
1	IN	Regulator Input. Supply voltage can range from 2.5V to 5.5V. Bypass with a $1\mu F$ capacitor to GND.
2	GND	Ground.
3	EN	Shutdown Input. A logic low reduces the supply current to 10nA. Connect to IN for normal operation.
4	BP	Reference-Noise Bypass(fixed voltage version only). Bypass with a low-leakage $0.01\mu F$ ceramic capacitor for reduced noise at the output.
4	FB	Adjustable voltage version only—this is used to set the output voltage of the device.
5	OUT	Regulator Output.



● **Typical Performance Characteristics**

$V_{IN} = V_{OUT}(\text{NOMINAL}) + 0.5V$  or  $2.5V$  (whichever is greater),  $C_{IN} = 1\mu F$ ,  $C_{OUT} = 1\mu F$ ,  $C_{BP} = 0.01mF$

$T_A = +25^\circ C$ , unless otherwise noted.

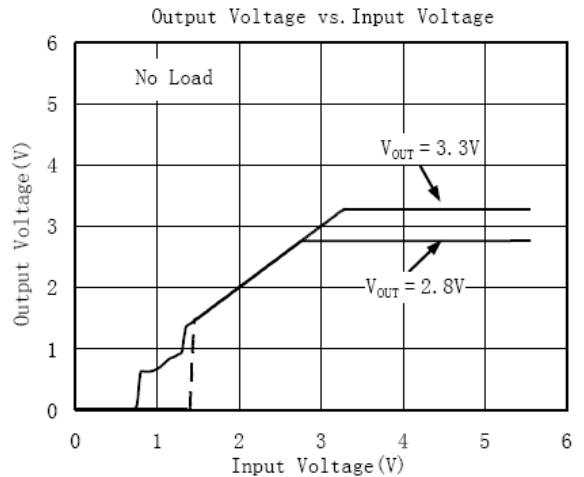
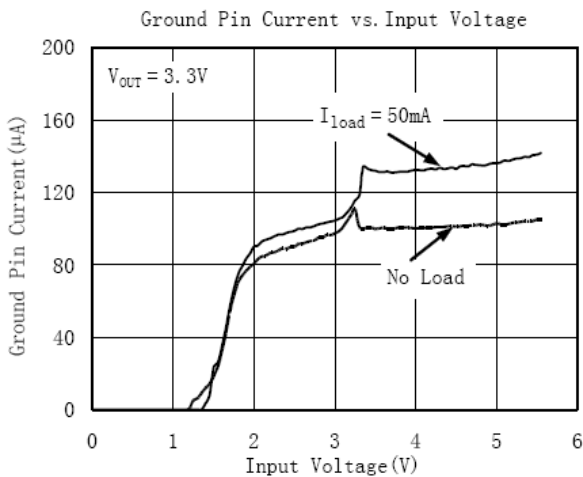
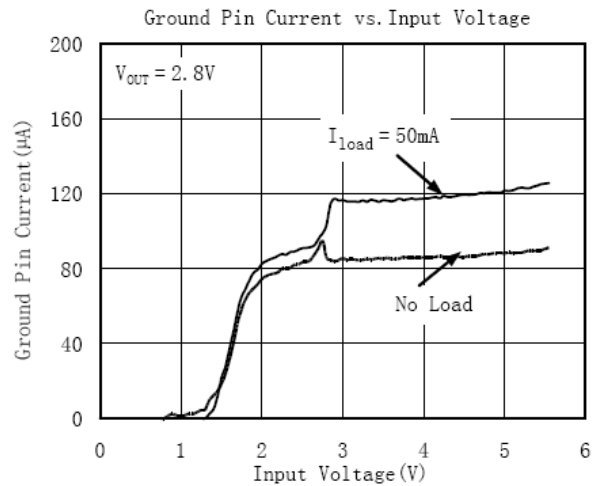
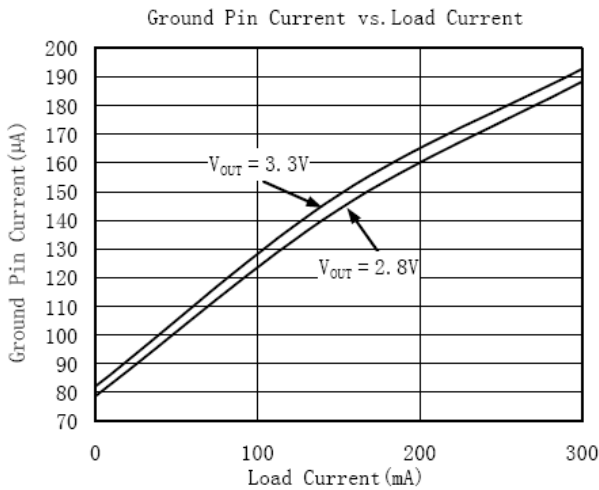
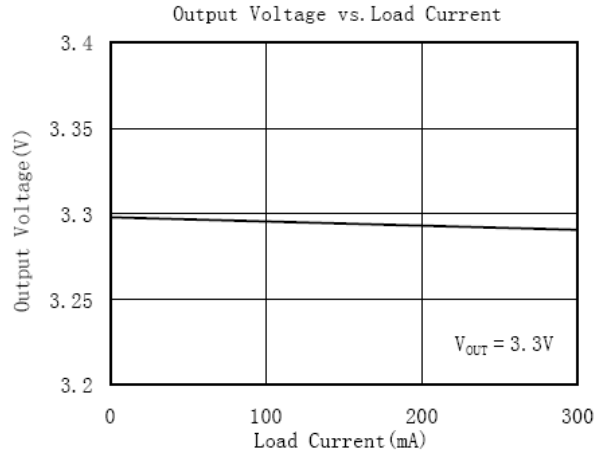
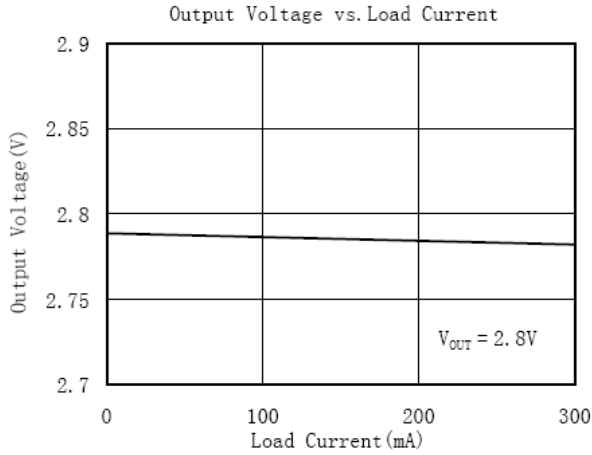

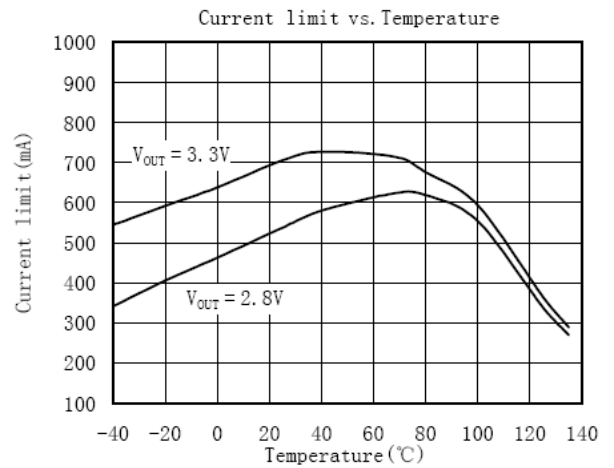
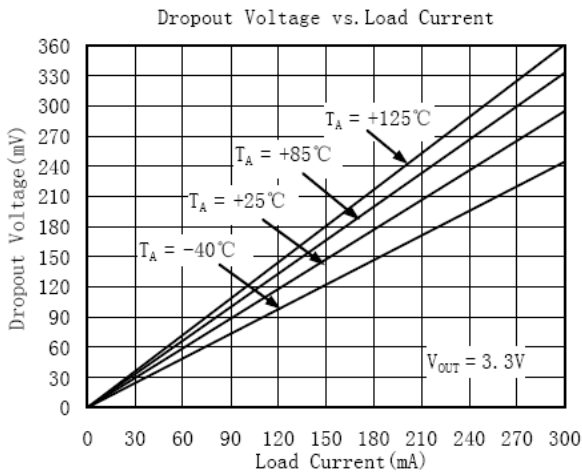
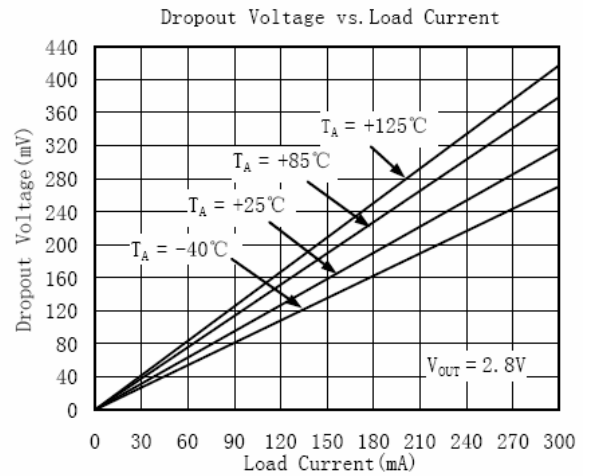
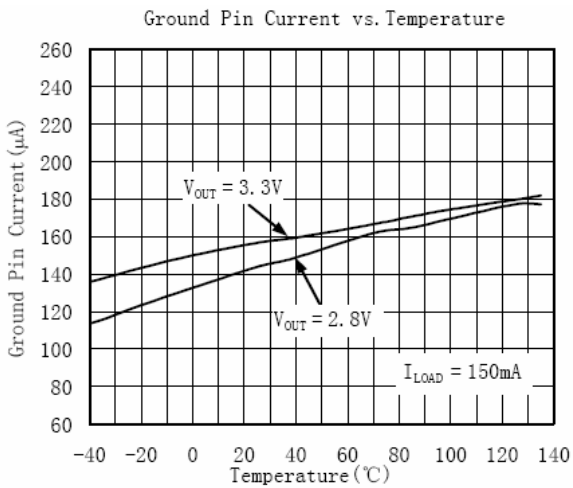
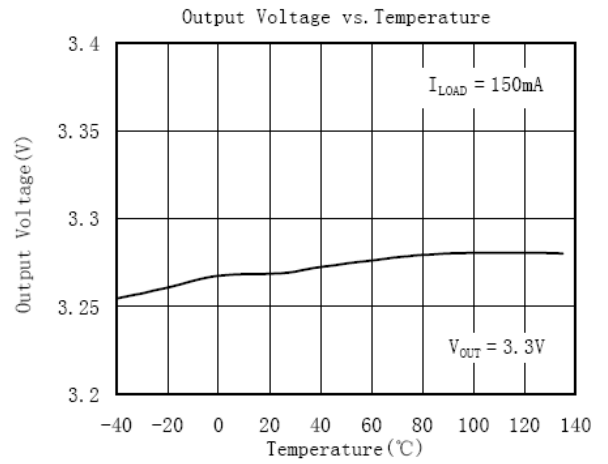
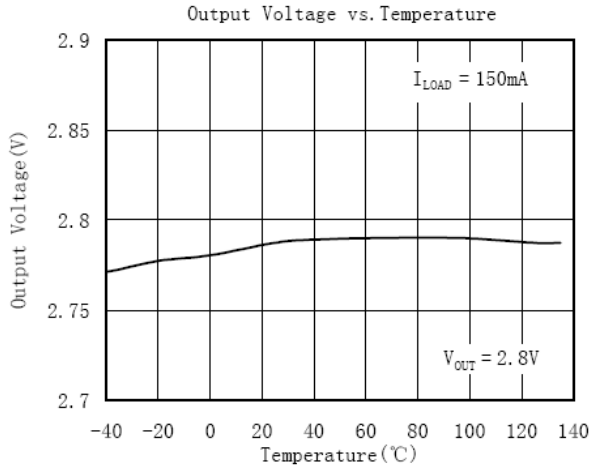

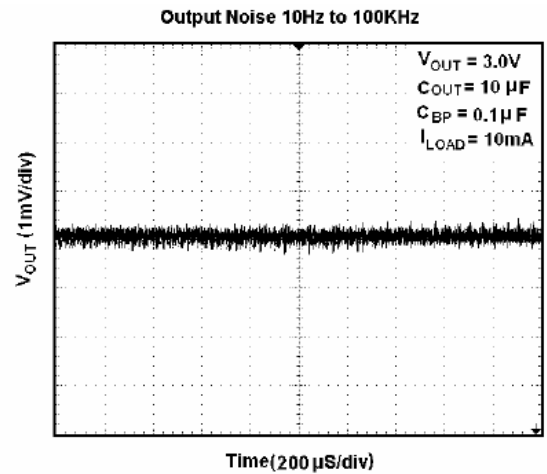
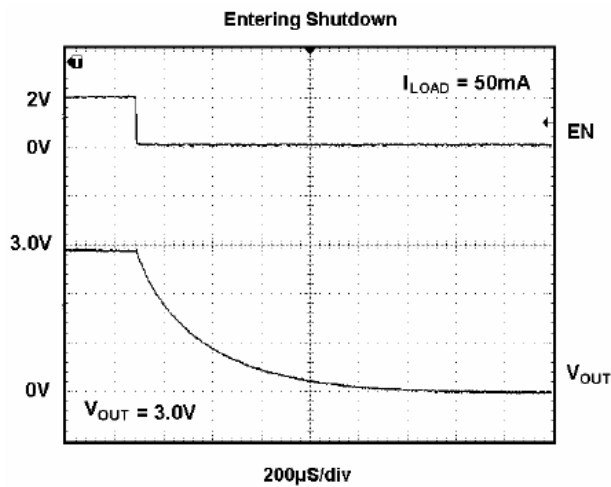
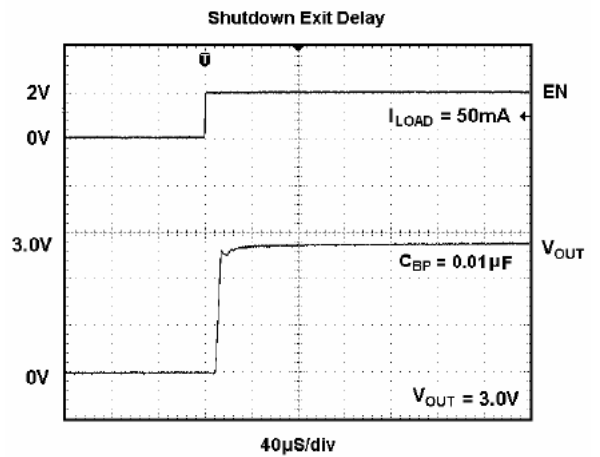
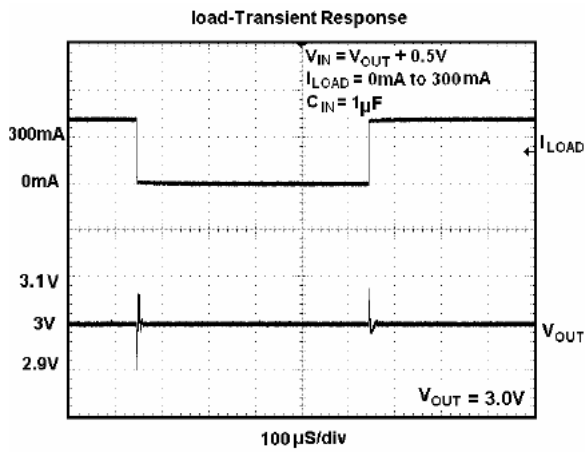
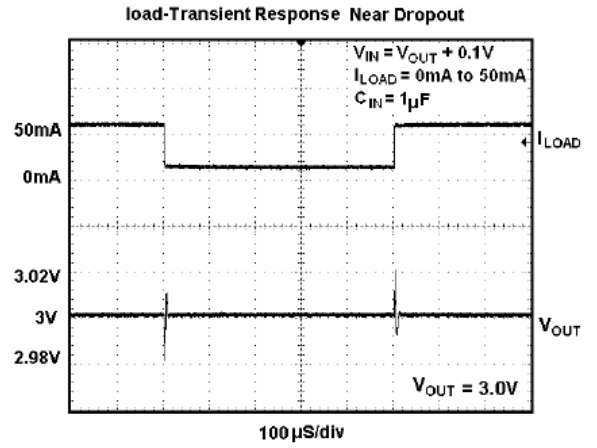
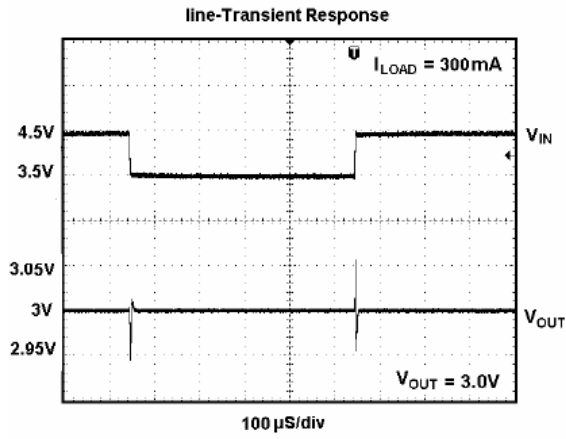

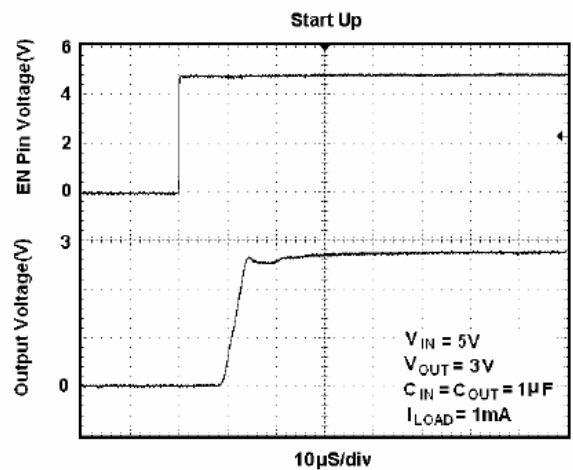
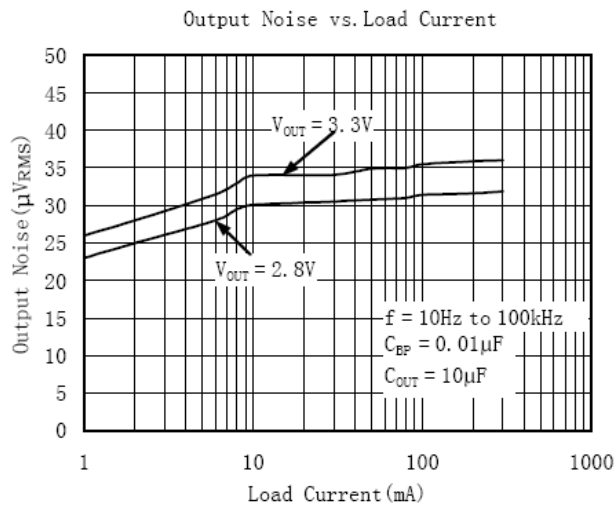
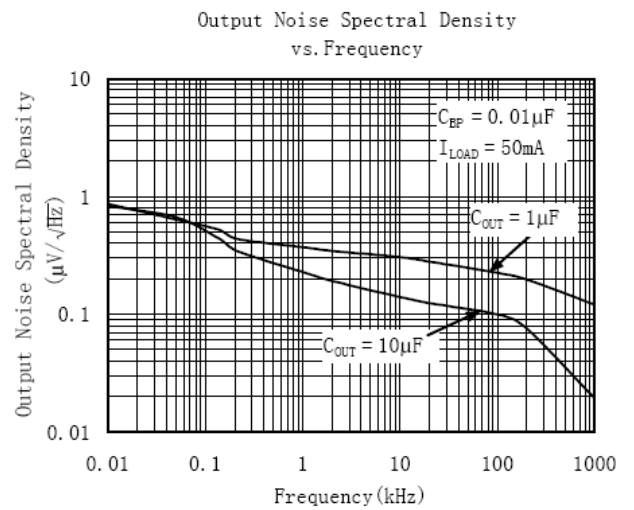
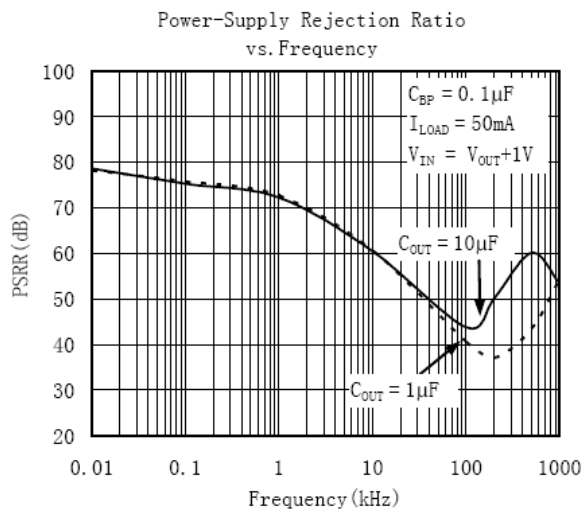



**FOR SEMI**

**FS3303B**

---





## ● APPLICATION INFORMATION

### INPUT CAPACITOR

An input capacitor of  $\geq 1.0\mu\text{F}$  is required between the FS3303B VIN and GND pin. This capacitor must be located within 1cm distance from VIN pin and connected to a clear ground. A ceramic capacitor is recommended although a good quality tantalum or film may be used at the input. However, a tantalum capacitor can suffer catastrophic failures due to surge current when connected to a low impedance power supply (such as a battery or a very large capacitor). There is no requirement for the ESR on the input capacitor, but tolerance and temperature coefficient must be considered in order to ensure the capacitor work within the operation range over the full range of temperature and operating conditions.

### OUTPUT CAPACITOR

In applications, it is important to select the output capacitor to keep the FS3303B in stable operation. The output capacitor must meet all the requirements specified in the following recommended capacitor table over all conditions in applications. The minimum capacitance for stability and correct operation is  $0.6\mu\text{F}$ . The capacitance tolerance should be  $\pm 30\%$  or better over the operation temperature range. The recommended capacitor type is X7R to meet the full device temperature specification.

Recommended Output Capacitor ( $C_{OUT}$ )

	TYP	MIN	MAX	Unit
Capacitance	1.0	0.6	10	$\mu\text{F}$
ESR		0	400	$\text{m}\Omega$

The capacitor application conditions also include DC-bias, frequency and temperature. Unstable operation will result if the capacitance drops below minimum specified value (see the next section Capacitor Characteristics).

The FS3303B is designed to work with very small ceramic output capacitors. A  $1.0\mu\text{F}$  capacitor (X7R type) with ESR type between 0 and  $400\text{m}\Omega$  is suitable in the FS3303B applications. X5R capacitors may be used but have a narrow temperature range. With these and other capacitor types (Y5V, Z6U) that may be used, selection relies on the range of operating conditions and temperature range for a specified application.

It may also be possible to use tantalum or film capacitors at the output, but these are not as good for reasons of size and cost.

It is also recommended that the output capacitor be located within 1cm from the output pin and return to a clean ground wire.

### CAPACITOR CHARACTERISTICS

The FS3303B is designed to work with ceramic capacitor on the output to take advantage of the benefit they offer: for capacitor values from  $1.0\mu\text{F}$  to  $4.7\mu\text{F}$  range, ceramic capacitors are the smallest, least expensive and have the lowest ESR values (which is good for eliminating high frequency noise). The ESR of a typical  $1\mu\text{F}$  ceramic capacitor is in the range of  $20\text{m}\Omega$  to  $40\text{m}\Omega$  that easily satisfies the ESR requirement for stability by the FS3303B.

For both input and output capacitors careful understanding the capacitor specifications is required to ensure correct device operation. The capacitor value can change greatly because of the operating condition and capacitor type. In particular the output capacitor selection should take account of all the capacitor parameters to ensure that the specification is satisfied for the application. Capacitor values can vary with DC bias conditions, temperature, and frequency of operation. Capacitor values will also demonstrate some decrease over time due to aging. The capacitor parameters are also dependant on the particular case size with smaller size giving poorer performance figures on general.

As an example, the following figure shows a typical graph showing a comparison of capacitor case sizes in Capacitance vs. DC Bias plot. As shown in the graph, as a result of the DC bias condition the capacitance value may drop below the minimum capacitance value given in the recommended capacitor table. It is also recommended that the capacitor manufacture's



specification for the normal value capacitor are consulted for all conditions as some capacitor sizes may not be suitable in the actual application.

The ceramic capacitor's capacitance can vary with temperature. The capacitor type X7R, which operates over a temperature range of  $-55^{\circ}\text{C}$  to  $+125^{\circ}\text{C}$ , will only vary the capacitance to within  $\pm 15\%$ . The capacitor type X5R has a similar tolerance over a reduced temperature range of  $-55^{\circ}\text{C}$  to  $+85^{\circ}\text{C}$ . Most large value ceramic capacitors ( $2.2\mu\text{F}$ ) are manufactured with Z5U or Y5V temperature characteristics. Their capacitance can drop by more than 50% as the temperature goes from  $25^{\circ}\text{C}$  to  $85^{\circ}\text{C}$ . Therefore X7R is recommended over Z5U and Y5V in applications where the ambient temperature will change significantly above or below  $25^{\circ}\text{C}$ .

Tantalum capacitors are less desirable than ceramic for use as output capacitors because they are more expensive when comparing equivalent capacitance and voltage ratings in the  $1\mu\text{F}$  to  $4.7\mu\text{F}$  range.

Another important consideration is that tantalum capacitors have higher ESR values than equivalent size ceramics. This means that while it may be possible to find a tantalum capacitor with an ESR value within the stable range, it would have to be larger in capacitance (which means bigger and more costly) than a ceramic capacitor with the same ESR value. It should also be noted that the ESR of a typical tantalum will increase about 2:1 as the temperature goes from  $25^{\circ}\text{C}$  down to  $-40^{\circ}\text{C}$ , so some guard band must be allowed.

## NOISE BYPASS CAPACITOR

Connecting a  $0.01\mu\text{F}$  capacitor between the CBYPASS pin and ground significantly reduces noise on the regulator output. This capacitor is connected directly to a high impedance node in the internal reference circuit. Any significant loading on this node will cause a change on the regulated output voltage. For this reason, DC leakage current through this pin must be kept as low as possible for best output voltage accuracy. The types of capacitors best suited for the noise bypass capacitor are ceramic and film. High-quality ceramic capacitors with either NPO or COG dielectric typically have very low leakage. Polypropylene and polycarbonate film capacitors are available in small surface-mount packages and typically have extremely low leakage current. The addition of a noise reduction capacitor does not affect the load transient response of the device.

## NO-LOAD STABILITY

The FS3303B will remain stable and in regulation with no external load. This is especially important in CMOS RAM keep-alive applications.

## ON/OFF INPUT OPERATION

The FS3303B is turned off by pulling the VEN pin low, and turned on by pulling it high. If this function is not used, the VEN pin should be tied to VIN to keep the regulator output on at all time. To assure proper operation, the signal source used to drive the VEN input must be able to swing above and below the specified turn-on/off voltage thresholds listed in the Electrical Characteristics section under VIL and VIH.

## FAST ON-TIME

The FS3303B output is turned on after Vref voltage reaches its final value ( $1.23\text{V}$  typical). To speed up this process, the noise reduction capacitor at the bypass pin is charged with an internal current source. The current source is turned off when the reference voltage reaches approximately 95% of its final value. The turn on time is determined by the time constant of the bypass capacitor. The smaller the capacitor value, the shorter the turn on time, but less noise gets reduced. As a result, turn on time and noise reduction need to be taken into design consideration when choosing the value of the bypass capacitor.