



90mΩ Current Limited USB Power Switches

● Features

- Input Voltage Range: 2.5V to 5.5V
- Fixed Current Limit
- Reverse Current Blocking
- Short-Circuit Response: 350ns
- Very Low Quiescent Current: 25µA (Typ)
- 1µA Max Shutdown Supply Current
- Under-Voltage Lockout
- Thermal Shutdown
- 4kV ESD Rating
- SOT23-5, TSOT23-5 Packages
- Ambient Temperature Range: -40°C to +85°C

● Applications

- Laptop/Desktop Computers and NetBooks
- 3G Wireless Cards
- Smart Phones and PDAs
- LCD TVs and Monitors
- Set-Top-Boxes
- MP3/MP4
- Printers
- Portable Game Players
- Portable Media Players and MIDs
- USB Keyboards
- USB Hard Disk Drives
- USB Memory Drives
- USB Hubs

● General Description

The FS9002 are current limited P-channel MOSFET power switch designed for high-side load switching applications. This switch operates with inputs ranging from 2.5V to 5.5V, making it ideal for both 3.3V and 5V systems. An integrated current-limiting circuit protects the input supply against large currents which may cause the supply to fall out of regulation. The FS9002 is also protected from thermal overload which limits power dissipation and junction temperatures. It can be used to control loads that require up to 1.7A. Current limit threshold is fixed internally. The quiescent supply current in active mode is only 25µA. In shutdown mode, the supply current decreases to less than 1µA.

The FS9002 is available in Pb-free packages and is specified over the -40°C to +85°C ambient temperature range.

● Pin Configurations (SOT23-6L)

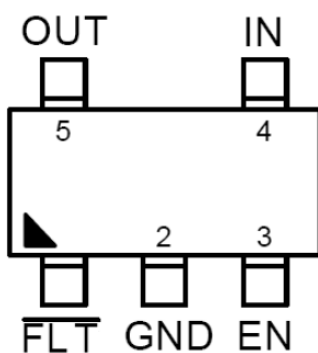

● Typical Application Circuit (VIN=2.5-5.5V)

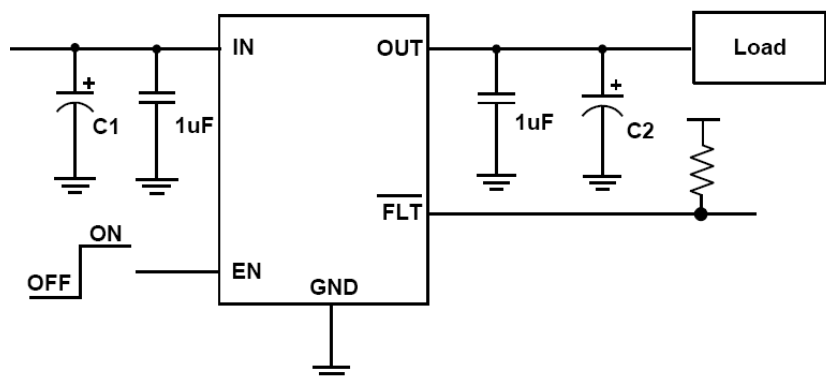



- Absolute Maximum Ratings**

Parameter	Rating	Unit
IN, EN,/FLT Voltage	-0.3 to 6	V
OUT Voltage	-0.3 to VIN + 0.3	V
OUT Current	Internal Limited	A
Junction to Ambient Thermal Resistance (θ_{JA})	150	$^{\circ}\text{C}/\text{W}$
Operating Junction Temperature	-40 to 125	$^{\circ}\text{C}$
Storage Temperature	-55 to 150	$^{\circ}\text{C}$
Lead Temperature (Soldering, 10 sec)	300	$^{\circ}\text{C}$

Note1: Production test at +25 $^{\circ}\text{C}$. Specifications over the temperature range are guaranteed by design and characterization.

- Electrical Characteristics**

(VIN = +5.0V, TA = -40 $^{\circ}\text{C}$ to 85 $^{\circ}\text{C}$, typical values at TA=25 $^{\circ}\text{C}$, unless otherwise stated)

Symbol	Parameter	Test Conditions	Min	Typ.	Max	Unit
VIN	Input Voltage Range		2.7		5.5	V
VUVLO	Input UVLO		1.8		2.5	V
ISHDN	Input Shutdown Quiescent Current	Disabled, VEN=0V, OUT floating or shorted to ground		0.1	1	μA
IQ	Input Quiescent Current /Channel	Enabled, VEN=VIN, IOUT= 0		25	40	μA
RDS(ON)	Switch on-resistance	VIN = 5V, IOUT= 0.6A, TA=25 $^{\circ}\text{C}$		90	120	m Ω
		VIN = 3.3V, IOUT= 0.6A, TA=25 $^{\circ}\text{C}$		110	140	m Ω
ILMT			1.8	2.2	2.6	A
VIL	EN Input Logic Low Voltage				0.8	V
VIH	EN Input Logic High Voltage		2.0			V
ISINK	EN Input leakage	VEN = 5V		0.01	1	μA
TD(ON)	Output Turn-on Delay Time	VIN =5V, CL=1 μF , Rload=10		10		s
TR	Output Turn-on Rise Time	VIN =5V, CL=1 μF , Rload=10		800		s
TD(OFF)	Output Turn-off Delay Time	VIN =5V, CL=1 μF , Rload=10		60		s
TF	Output Turn-off Fall Time	VIN =5V, CL=1 μF , Rload=10		20	200	s
TFLT_BLANK	FLT Blanking Time			4		ms
VFLT_Lo	FLT Logic Low Voltage	IFLT(SINK) =1mA			0.4	V
IFLT	FLT Leakage Current	VFLT = 5V, Enabled, No Fault Conditions		0.1	1	μA
Rdischrg	Output discharge FET Rdson	VIN = 5V, EN=0V, VOUT=5V		100	200	Ω
TSHDN	Thermal shutdown threshold	VIN = 5V		135		$^{\circ}\text{C}$
THYS	Thermal shutdown hysteresis	VIN = 5V		15		$^{\circ}\text{C}$





- **Typical Block Diagram**

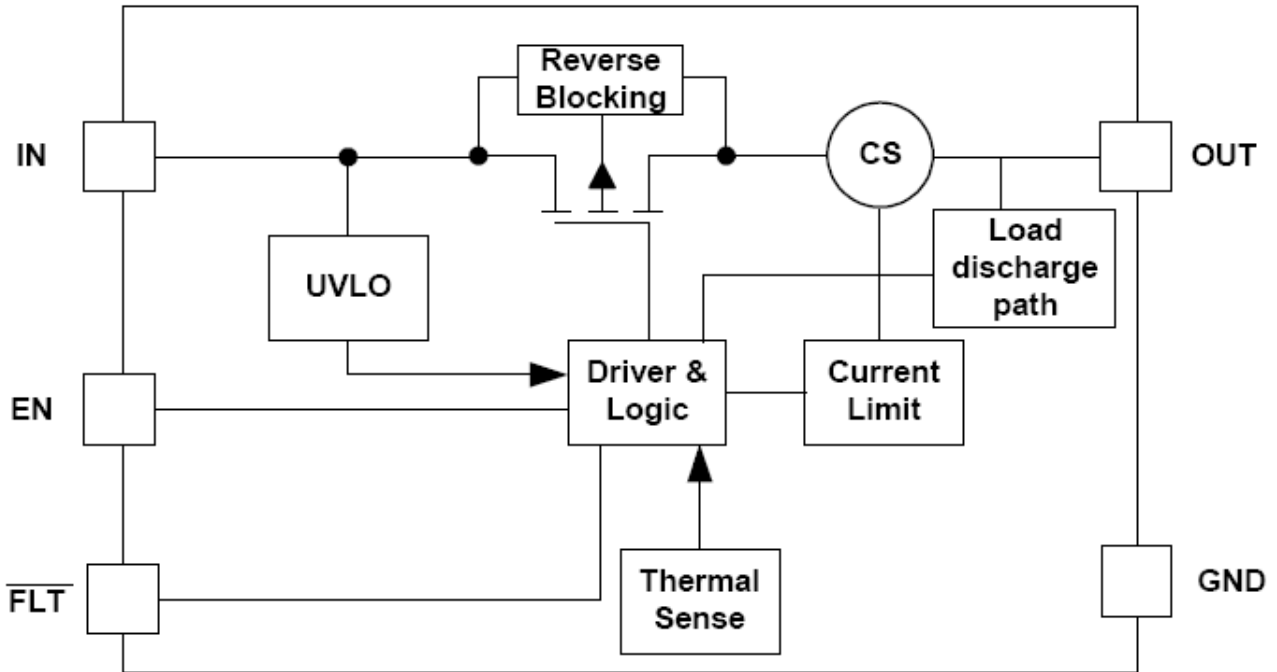

- **Pin Description**

Pin No.	Pin Name	Pin Function
1	/FLT	Overcurrent and over-temperature fault reporting signal output, active low with 4.5ms blanking time for overcurrent conditions and 0ms blanking for over-temperature conditions.
2	GND	Ground Pin
3	EN	Enable input
4	IN	Power supply input. Must be closely decoupled to GND pins with a 1 μ F or greater ceramic capacitor.
5	OUT	Power output. A discharge FET is connected to the OUT pin when the device is disabled by EN pin or the input voltage is below UVLO threshold.

- **Application note:**

FS9002 is an integrated power switch with a low $R_{ds(on)}$ P-channel MOSFET, internal gate drive circuit, programmable current limiting, and thermal protection. When the FS9002 turns on, it can deliver up to 1.2A continuous current to load. When the device is active, if there is no load, the device only consumes 25 μ A supply current, which makes the device suitable for battery powered applications.

Power Supply Considerations

A 0.01- μ F to 0.1- μ F ceramic bypass capacitor between IN and GND, close to the device, is recommended. Placing a high-value electrolytic capacitor on the output pin(s) is recommended when the output load is heavy.



This precaution reduces power-supply transients that may cause ringing on the input and minimize the input voltage droops. Additionally, bypassing the output with a 0.01- μ F to 0.1- μ F ceramic capacitor improves the immunity of the device to short-circuit transients.

Power Dissipation and Junction Temperature

The low on-resistance on the P-channel MOSFET allows the small surface-mount packages to pass large currents. It is good design practice to check power dissipation and junction temperature for each application. Begin by determining the $R_{DS(ON)}$ of the P-channel MOSFET relative to the input voltage and operating temperature. Using the highest operating ambient temperature of interest and $R_{DS(ON)}$, the power dissipation per switch can be calculated by: $P_D = R_{DS(ON)} \times I_2$ Finally, calculate the junction temperature: $T_J = P_D \times R_{JA} + T_A$ Where: T_A = Ambient temperature R_{JA} = Thermal resistance P_D = Total power dissipation Compare the calculated junction temperature with the maximum junction temperature which is 125 °C. If they are within degrees, either the maximum load current needs to be reduced or another package option will be required.

FLT Output

The FAULT Flag (FLT) is provided to alert the system if a FS9002 load is not receiving sufficient voltage to operate properly. If current limiting circuit is active for more than approximately 4ms, the FAULT Flag is pulled to ground through an approximately 100 Ω resistor. The filtering of voltage or current transients of less than 4ms prevents capacitive loads connected to the FS9002 output from activating the FAULT Flag when they are initially attached. However, if the device is entering over-temperature conditions, the FLT will be pulled low without delay or deglitch. Pull-up resistance of 1k Ω to 100k Ω on FLT pin is recommended. Since FLT is an open drain terminal, it may be pulled up to any unrelated voltage less than the maximum operating voltage of 5.5V, allowing for level shifting between circuits.

Thermal Protection

Thermal protection prevents damage to the IC when heavy-overload or short-circuit faults are present for extended periods of time. The FS9002 implements a thermal sensing to monitor the operating junction temperature of the power distribution switch. In an overcurrent or short-circuit condition, the junction temperature rises due to excessive power dissipation. Once the die temperature rises to approximately 135°C due to overcurrent conditions, the internal thermal sense circuitry turns the power switch off, thus preventing the power switch from damage. Hysteresis is built into the thermal sense circuit, and after the device has cooled approximately 15°C, the switch turns back on. The switch continues to cycle in this manner until the load fault or input power is removed.